

# ***2025 PASS MODS Rules***

**Chassis** May be straight rail or a perimeter chassis with a minimum wheelbase of 107" maximum left side weight of 58% and Total weigh of a minimum of 2600lbs.

## **Center Section Components:**

- a. Main frame rail structure of chassis, defined as the primary structure to which roll cage members, major suspension components, engine, etc., mount, must be constructed of a mild steel shape having a minimum perimeter dimension of 10 inches. Examples: 2 x 3, 2 ½ x 2 ½ , etc. Main frame rail members should be a minimum of:
  - b. . 10-inch perimeter tubing: 0.120-inch wall thickness
  - c. . 12-inch perimeter tubing: 0.095-inch wall thickness
  - d. . 16-inch perimeter tubing: 0.083-inch wall thickness
- e. Main frame rail members shall be constructed so that the side rails are located within the normal tread width of the car. Right side main frame rail may be a perimeter or straight rail design.
- f. The left main frame rail on all chassis must measure a minimum of 10" perimeter around the left front frame rail. No cutting for frame height clearance.

## **Roll Bars:**

- a. A four-point roll cage structure of 1 3/4 inch outside diameter made of 0.090-inch-thick chrome moly or mild steel tubing is required. All cars must have an x-type member across and behind the driver.
- b. Roll cage structure must be fully with minimum 1/8-inch-thick gusset plates at all major tube intersections.
- c. A minimum of 4 horizontal bars, 3 curved, with 6 vertical bars (2 between each horizontal bar), with steel gussets is required in the driver's door.
- d. It is mandatory to have 16-gauge metal welded between door bars or a 16-gauge plate 40 inches in length and 17 inches high minimum, welded between the door bars and the driver's door.
- e. The right-side door shall have 3 horizontal bars, straight or curved.
- f. Total height of roll cage to be 40 ½ inches from bottom of the frame. Halo will be no less than 1 inch lower.
- g. There must be a piece of tubing welded diagonally or perpendicular between halo and top of roll cage.
- h. Minimum height of door bars on driver's side is 22 ½ inches from bottom of frame.
- i. A "Petty Bar" must run between center of cage and upper right front halo.
- j. Width of halo should be a minimum of 29 inches. Measurements will be from outside to outside of tubing older cars may be grandfathered with PASS approval. Contact **Jason Ricker (704-881-4429)**
- k. No brace bars forward of the main 4-point cage may be higher than stock hood height.
- l. All roll cage installations and workmanship must be acceptable to PASS Officials.

## Front Clips

1. **Stock Clip:** Factory production full 1968 or newer perimeter American passenger car front frame clip only. No modifications to clip permitted except for upper control arm mounting, spring pocket boxing for clearance of use of coil over mount shock/spring, radiator clearance and mounting and trimming of forward front cross member for center link clearance.
  - a. **Horns:** May be fabricated using 2X3" tube. Steering box MUST be in Factory location.
  - b. **Crossmember:** NO cutting, raising, shortening, of factory front cross member. If yours has been cut, then a 1/8" plate must be welded to the bottom and replicate the **stock location**.
  - c. **Upper Control Arm Mounts:** Mounting point may be relocated.
  - d. **Suspension Points:** No alterations to OEM mounting points.
  
2. **Tube Clips:** A fabricated 2x4, 12-inch perimeter tubing; 0.095-inch wall thickness "F" body Camaro front clip will be permitted without weight penalty. Measurements and Template from the Howe 358-8-01 will be used as a "GO/NO GO" gauge. This clip is designed for Stock lowers and steering box placement and use. Clip must retain 2x4 box from front to rear. NO 2x3 step in suspension area.

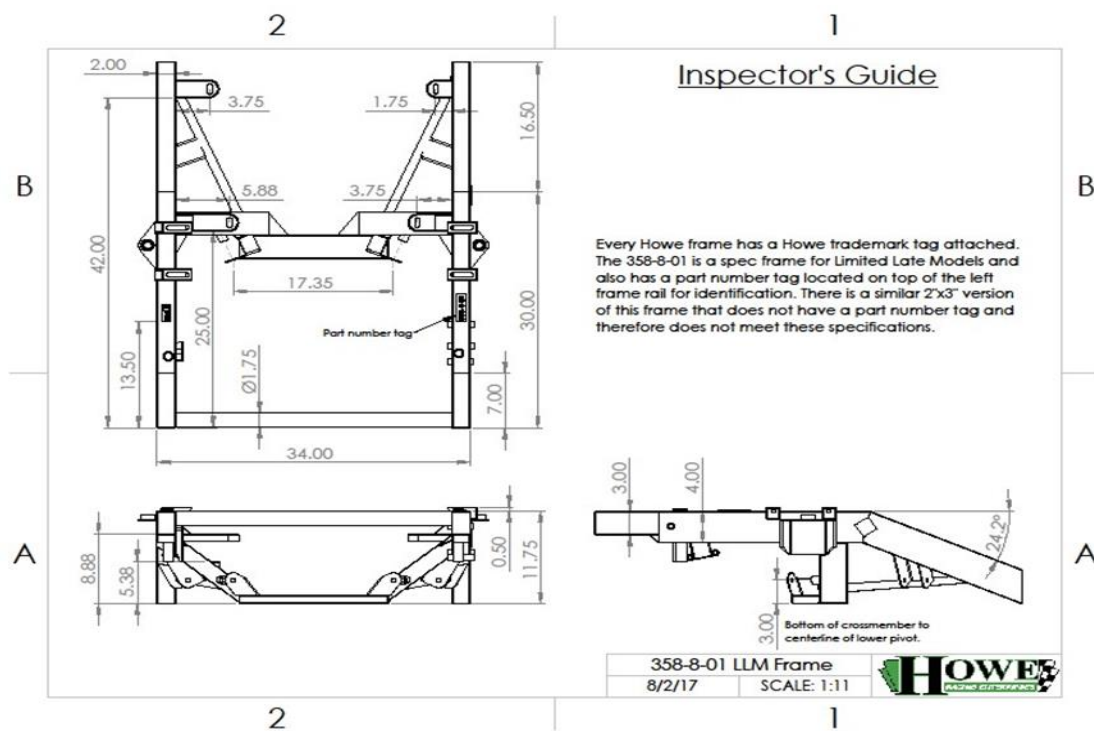

Any clip not matching **ALL** these dimensions will be reviewed by PASS Tech staff and will add weight as needed or asked to not run.

**Rear Clips:** Frames may be leaf, coil spring, or coil-over. The rear frame section must extend beyond the rear edge of the fuel cell. The rear frame section maybe be 2" X 2" from the rear axle rearward. Rear frame section may be fabricated above or below the rear axle.

**Fuel Cell:** must be a steel container with a check/rollover valve in the vent line; secured with two (2) straps front to rear and two (2) straps left to right. The minimum dimension of strap material is eighth (1/8) inch x one and one half (1½) inch. Fuel cell may not be offset. **Cell must be a minimum of 8" above the track and 11" from rearend tube to front of cell.**

**Bumpers:**

**Rear:** Rear bumpers may be constructed of tubing, channel, or flat stock, and must protect fuel cell. Center of bumpers (front and rear) must be 18" from ground (Tolerance 2"). Rear bumpers and nerf bars, must not extend more than one inch beyond width of rear tires and must not contain any sharp edges. Rear bumper tethers or safety cable is mandatory, must be attached to both bumper and rear chassis to prevent bumper from being dislodged.

**Front:** Maximum front bumper length not to exceed 18 inches from mounting point on chassis. Front bumper must be mounted frame end to frame end, with bottom loop parallel to the ground. Minimum 1 ¼" round tubing and able to support car if lifted by wrecker.

**Drivers Box:** The driver compartment tub (to the right and to the rear) to be constructed from a minimum of twenty-two (22) gauge steel or .040 aluminum. The driver foot box and firewall to be constructed of a minimum of twenty-two (22) gauge steel. The area immediately beneath the driver, floorboards, foot box and the vertical panels surrounding the seat area (front and rear firewalls and transmission tunnel) must be constructed of twenty-two (22) gauge steel and be of welded construction.

**Height:** Minimum height of lowest point to ground is 3"

**Weight:** Total base weight will be a minimum of 2580.

**Seat:** Aluminum racing seat with right and left head supports. Seat must be mounted and attached securely to the cage. A support brace must be installed at the rear of the seat. **The head should be below halo and clear of all roll bars.**

**Seat Belts:** Mounted with three eighths (3/8) inch bolts minimum Grade 8 washers and locking nuts. These must be attached at two (2) separate points on the frame, equal distance from the seat back and not less than twelve (12) inches apart. (See manufacturer instructions for details).

**Steering Column:** A fabricated steering column must have a minimum of two (2) U-joints positioned so as not to allow the steering wheel to be pushed rearward in the event of a collision. Must have steering column stop. All steering wheels must have a center pad.

**Welds:** All welds are to be of high quality and must surround the joint completely.

**Wheelbase:** Minimum wheelbase of 107"

**Bodies:** Bodies may be Tempo, Cavalier, Mustang, Daytona, Gremlin, etc. American passenger cars only. No panel vans or station wagons. Must be full sized roof. No side skirts. Bodies will not extend beyond the back of the engine block.

1. **Panels:** Fiberglass or metal duplicate of body parts are permitted. Handmade or aftermarket body parts may be constructed of steel, aluminum, or fiberglass.
2. **Roof:** Must be a minimum of 44 inches from ground with car at three (3) inch frame height. The original roof line of vehicle shall be maintained with a maximum two (2) inch drop, rear to front. The roof must be a minimum of 40 inches wide. Five Star pavement modified roof as manufactured allowed.

3. **Air Flow Devices:** No air flow devices allowed. No wings or ground effects allowed inside or outside of vehicle. Vertical or airfoil or any other aerodynamic devices will not be permitted anywhere on the car. No undercar panning permitted.
4. **“B” Pillar:** No add-ons to the fore side of pillar.
5. **Sail Panels:** Must end a minimum of twelve (12) inches forward of spoiler and be one continuous straight line of taper down to a maximum height of two (2) inches at trailing edge.
6. **Height:** No body part may be closer than three (3) inches to the ground.
7. **Width:** No part of the body can exceed 66 ½”
8. **Quarter:** Panels behind rear axle housing must maintain a minimum ground clearance of eight (8) inches.
9. **Deck Lid:** The deck lid must remain no lower than the bottom of the spoiler and carry forward at least thirty (30) inches in a parallel form. The rear deck is not too sunk down and used as an additional spoiler or air deflection device in any way.
10. **Door:** Maximum height of door/quarter ledge is thirty-four (34) inches measured from the ground to top edge.
11. **Engine Compartment:** Engine compartment will remain open. No side panels.
12. **Hoods:** Hood sides may have a maximum four (4) inch drop and must be enclosed at rear edge.
13. **Interior:** Panel on right side of car may extend from the top of the transmission tunnel to a height of not less than one (1) inch below the top of door.
14. **Nose:** Panel max width is forty-two (45) inches and may not extend further than bumper. Front nose is to be no higher than the top of the air cleaner at any point.
15. **Quarters:** Must not exceed sixty-six (66) inches between the right and left quarter.
16. **Right Rear Quarter:** Panel to be no further away than two (2) inches to the inside of the inner sidewall of tire and must be eight (8) inches from the track surface.
17. **Rear Deck:** Deck lip not to extend more than forty-five (45) inches behind center of rear axle and to be the same height as quarter panels as not to act as air tunnel for spoiler.
18. **Spoiler:** Must be centered on the back of the car on the rear quarters and deck lip meet. No boxing permitted. The top four (4) inches of spoiler must be made of clear Lexan. Competitors must be able to see through spoiler. Deck lip must be seventy (70) to ninety (90) degrees of spoiler.
19. **Height:** Maximum rear spoiler height from ground to topmost edge is thirty-nine (39) inches.
20. **Size:** Blade surface five (5) inches x sixty-six (66) inches
21. **Tail Piece:** Rear of bodies to be solid panel at least eight (8) inches. Must touch bottom edge of rear deck lid and be at a ninety (90) degrees angle to track surface.
22. **Windows:** Must have full or half Lexan windshield. Windshield must go from roof to dash, and from “A” pillar to center line of roof.
23. **Side:** Both side windows must have a minimum of twelve (12) inches vertical opening from front to back.
24. **Carbon Fiber or exotic Material:** No Carbon fiber or any like materials will be allowed in the PASS mods.

## Engine Requirements:

### Crate Engine Inspection Policy

Within the guidelines of utilizing the 'Crate'-Race engine options for all competitors are subject to a zero-tolerance policy of inspection and conformability to all guidelines as specified by the manufacturer. If in the event any team is considered in question as to the productivity of performance from a 'crate' powered engine, that engine will be susceptible to the following inspection process without protest. Failure to adhere to any action taken by PASS series officials will result in immediate disqualification. At the conclusion of any race event PASS reserves the right to require any team to remove engine in complete form and turn over possession to appropriate officials for inspection purposes to be determined by officials. Engine will be susceptible to Dyno testing and/or engine tear down for complete inspection to determine total legality to factory produced complete form. In the event ANY part within engine is found non-conforming, the entire engine will become the possession of PASS without claim or dispute. An additional \$1,000.00 fine will be assessed to violating team before next event in which said teams attempts to compete.

**Crate Option1: 2575lbs GM crate engine p/n 88958602**

**2600lbs GM crate engine p/n 88958602 w/pan change**

This is the PASS sealed Bottle Cap Crate delivered straight from GM and has been sealed with PASS seals by LCM racing Engines. The motor must remain as delivered with all stock parts to include the Harmonic balancer and oil pan. The engine will have a option to go through a brake in process to include dyno time with brake in oil, get its first oil change, valve adjustment, and timing mark correction if needed before delivery. In the event of the motor needing any replacement of internal gaskets or internal parts this will now become a rebuilt option and will carry the extra weight. **These engines will have a claim option to any competitor in competition that day for the same value as the purchase of a new motor. The claimed motor will be the price on that day and will come as delivered from LCM Racing Engines. No Carburetor, Distributer, clutch assembly, front drive pulleys or fuel pump are included in the claim option.**

**Crate Option 2: 2625lbs**

GM crate engine p/n 88958602 The only changes are as follows.

Maximum overbore of .008"

Maximum Deck surfacing of block: .005"

Maximum deck surfacing of cylinder head: .005 straight only. NO angle milling permitted.

Minimum rod and main bearing size: .010" under All other necessary parts required for rebuild are to be direct factory replacement purchased through Manufacturer and are exact OEM specified part numbered to engine utilized specification sheet and installed to factory-built specs. NO EXCEPTIONS! All crate engines are to be used in complete form as produced unless otherwise specified. From Intake manifold to oil pan. No external oiling systems permitted. ZERO TOLERANCE!

**Timing Chain:** The timing chain set may be replaced with a double roller set.

**Oil Pan:** Replacement oil pan Moroso p/n 21319 7.125 depth and matching oil pump p/u assembly or gm factory 604 oil pan part number 25534354 used with 1/8" thick plate tack welded to the bottom of the pan to equal the same depth as the Moroso p/n 21319 7.125 (gm 25534354 7" depth + 1/8" plate = 7.125 total)

**Carburetor:** A stock unaltered PASS approved Holley 600 CFM or Holley HP Series 4 brl 650 Carburetor (p/n 80541-1, -2, or-3). The only allowable alterations are Jet sizes (jet extensions are ok), power valve, and top bleeds.

Booster# 45R-312.

Metering block #11978.

Accelerator pump Assy #34R-12684B.

Carb Bowl #34R-12682B.

### **Built Motor Option: 2700lbs**

2 Barrel engine option specifications

**Block:** stock, maximum .045 overbore production blocks only. No angle milling permitted. Only modifications permitted are standard boring and decking only.

**Crankshaft:** stock production steel only. Stock stroke =/-.020. No Knife edging or lightening permitted. Only nominal engine balancing permitted. Minimum allowable weight shall be 50 lbs. Rod and main journals must remain OEM size.

**Camshaft/Lifters:** Hydraulic cam and lifters only. The maximum allowable cam lift is .450 measured at the valve. Roller bearings are NOT permitted. No roller cam/lifters.

**Pistons:** Flat top skirted pistons only. Maximum allowable compression is 10.99 to 1. 2 or 4 valve pocket full skirted pistons permitted. Piston may not protrude above edge of cylinder block surface.

**Connecting Rod:** Stock or sportsman type connecting rods only. Stock length for engine used.

**Oil pan:** racing type pans allowed. Wet sump only. Maximum 7-quart capacity. Minimum depth of pan from mounting rail to base of pan shall be 7 inches.

**Oil Pump:** Factory stock mounted internal wet sump type only.

**Intake:** Factory cast iron 2 barrel, or the following Edelbrock performer intakes are permitted. G.M.= 2101, 2116, 7116. No porting, polishing or modifications permitted (Including chemical porting). Port matching is NOT permitted.

**Cylinder heads:** Stock production steel cylinder heads only. No bowtie allowed. Heads must remain stock except for the Installation of screw-in rocker arm studs and push rod guide plate



installation permitted. Maximum valve spring outside diameter shall be 1.250 inch. Head must retain stock valve size for casting used. Maximum Intake valve diameter 1.94". Maximum Exhaust valve diameter 1.50". Stud girdles are not permitted. Angle milling is NOT permitted.

- No porting, polishing or modifications permitted (to include chemical porting). Port matching is NOT permitted.
- Roller rockers are permitted. 1.5 ratio only.
- Timing Chain: Stock replacement or double roller chain permitted.
- Harmonic Balancer: Stock production only.
- Maximum engine static compression permitted is limited to a maximum of 10.99 to 1.
- No Aluminum or Titanium parts permitted unless otherwise listed.
- Any specific part not listed within these posted rules must remain O.E.M. manufacturer replacement parts only.

**Carburetor:** Holley 4412 2barrel. The only modifications allowed to carburetor will be the removal of choke plate and shaft. Maximum 1 inch carburetor spacer only. no tapered or beveled spacers permitted. I.D. must remain consistent through spacer depth from top to bottom.

The Built engine option with a PASS approved Holley 600 CFM or Holley HP Series 4 brl 650 Carburetor (p/n 80541-1,-2, or-3) is permitted at a competition weight of 75 lbs more than permitted crate engine option for initial competition.

**Exhaust System:** Exhaust system must be mounted in such a way as to direct spent gases away from areas of possible spillage of fuel. Headers may be used but must be pointed away from the ground. All cars must have a **Schoenfeld p/n 112535 a 3.5x11 or 112530 a 3.0x11 muffler**, passing a maximum of 100 decibel noise test 50' from the track. Exhaust may exit by the nerf bars but may not extend beyond them. Exhaust must be collector type header. No 180-degree headers allowed. The left exhaust header must exit on left, right header on right side. Only headers allowed are IMCA type - no crossover headers.

**Air Filter:** Maximum size 17 inches outside diameter by 4 inches high. No flow enhancers or cold air induction permitted. No notching of cowl, back of hood must seal to cowl top.

**Fuel Pumps:** Only stock mechanical fuel pumps mounted in a stock location. No electric fuel pumps.

**Fuel:** Only Sunoco standard (purple) race fuel permitted or pump gas only.

**Engine placement:** Stock motor mounts may be replaced with solid mounts. Motor must be a minimum of 72 inches from the center of the rear end to the rear of the engine block. Engine offset must be kept within 2" of the centerline of the cross member (within 1" of center). Minimum Crank height from center of crank to ground 11".

**Ignition system:** GM HEI stock type distributor only. Any battery powered ignition system produced for highway use is allowed. No crank trigger systems, no magnetos, boosters, or other devices allowed. One working coil only. No aftermarket electronic ignitions allowed. No systems

with external box allowed. Battery must be securely fastened inside the main frame rails and outside of cockpit. Must have a Master on/off switch clearly marked within reach of driver's door.

**Cooling system:** System may be modified. No anti-freeze permitted. Only belt driven block mounted OEM similar design water pumps permitted. Belt driven fan blades or electric cooling fans are permitted.

**Power Steering:** Aftermarket racing power steering pump and any design tank are permitted.

**Driveline:**

**Transmissions:** Only OEM production type transmissions will be allowed. 3 speed or 4 speed and automatic. No 5 speed. No in and out boxes. No buttons or couplers. Must be clutch operated. Clutch or torque converter must be inside of bell housing. Shifting with motor running imperative! No Jericho type or straight cut gear type transmissions permitted. Transmission must have at least two gears forward and one reverse gear and must have neutral. All race cars must join lineup on demand, unaided, or go to rear of race. 4th gear must be 1 to 1. No other gear may be Higher than 1.23 in the transmission.

**Clutch:** If using stock type clutch, car must be equipped with explosion proof steel bell housing. Multiple disc clutches are permitted. Minimum disc diameter is 7 1/4 inches, steel discs and pressure plates only, must mount to back of engine in stock location. Any steel flywheel permitted. Clutch must be mounted inside of bell housing. **Reverse mount starter and Bell housing can be used with an added 25lbs.**

**Starter:** Car must be self-starting. If the car doesn't start and needs a push car will re-join the tail of the field once running.

**Driveshaft:** Driveshaft must be steel only. Painted white.

Drive shaft loop is required and must be constructed of at least 1/4 inch X 2" steel. Must be mounted no more than 6" back from front of driver shaft.

**Gear rules:** Maximum 5.38 direct or final drive. For tracks 1/2 mile or larger a gear rule will be mandated.

**Rearends:** Rear ends must have floating type bearing and hub

1. **Ford Nine option:** A steel Nine inch rear no Aluminum centers sections. The gear assembly must be steel with steel gears.
2. **Quick Change:** A quick change rear end with an aluminum center section steel tube with weld on 0 degrees cambered pins will be allowed in 2023. This must be a 10" ring gear with a spool only.

Both rears must follow the following guidelines

- a. No exotic metals steel only.
- b. Mini spool or open differential
- c. No Camber or toe built in
- d. Steel drive plate and axel caps
- e. Minimum Axel diameter 1.200 and weigh 7lbs
- f. No crowned axels



**3 Suspension:** Suspension: Front suspension must be in stock location. Heim ends permissible.

**BUSHINGS:** Lower control arm bushings are limited to stock, steel, or neoprene type only. No spherical bearing or heim end bushing type permitted.

**Lower Control Arms:** Any OEM stamped stock unaltered lower “A” frames can be used with a max offset of 1” side to side.

**Upper:** Tube type upper “A” frame allowed, can be moved and adjustable. Jacking bolts allowed.

**Materials:** No titanium, or carbon fiber parts are permitted.

**Steering:** Steering box must be OEM. Must utilize 700 series steering box only. NO rack and pinion. No aftermarket design steering box. Must remain within original bolt pattern for type of frame used.

**Pitman Arm:** Stock or aftermarket similar replacement.

**Idler Arm:** Stock or Howe replacements

**Spindles:** Stock passenger car spindles only. No fabricated spindles. No alterations (welding or heating) allowed on spindle arms. No Howe cast spindles. Aftermarket dropped spindles are permitted but are limited to the following: Bell tech P/N 2100 and Classic performance P/N 7078ds. Aluminum spindles are not permitted.

**Springs:** Conventional coil spring and shock, or coil-over suspension allowed. All springs must be magnetic steel only. Only one spring per shock not to include a bump spring.

**Weight Jacks:** Must be in original centerline with coil springs. No hydraulic, ratchet, or electric weight jacks anywhere in or on car. “No Bird Cages”.

**Sway Bars:** Sway Bar: Sway bar may be stock, one-piece aftermarket or 3-piece aftermarket design. All components must be steel. Rear sway bars are not permitted.

**Third Link:** The rear center link may be a solid link or mounted in rubber bushings. No spring third links permitted.

**Tie Rods:** All rod ends are to be steel. Tube type tie rods ends permitted.

**Tread Width:** Maximum tread width front and rear is seventy-six (76) inches, measured from outside of wheel edge to outside of wheel edge as measured at the bead lip of the wheel. The front is measured at the front of the wheels; the rear is measured at the rear.

**Traction Control:** No traction control of any kind.

**Trailing Arms:** No spring-loaded arms permitted.

**Shocks:** Bilstein shocks with a Max rebound of 12 will still be allowed at an added weight of 25lbs in 2023 and go up in 2024 to 50lbs as we work to faze these shocks out to make room for the new Spec shock for the Modifieds. The WB series and Afco 14 series can be used as supplies last with no penalty.

**Spec Shock: QA1 63 series**

Fronts Only	Rears Only
6375-400	6394
6375-500	6394-6
6375-650	6395-3
6375-750	

6375-850

Must be used out of the box with **ZERO TOLERANCE** for tampering. **NO bending tweaking or modify of any kind if found before or after the race automatic DISQUALIFICATION from event and possible fine.**

**\*\*With supply assurances from QA1, this is the shock that will become the spec shock of this division as we fade out other part numbers.**

**There will be a \$250 claim rule for shocks. All claims must be from competitors racing that night and approved by PASS Tech staff. Claim to include shock only. Spring, spring retainer, and bump stop hardware not included.**

**Brakes:** Front hubs must be of stock OEM heavy duty type or aftermarket steel replacement safety hubs. Rear may be either stock, flange hub type or hat design. Must be steel. Aftermarket type must as produce and be a minimum .810 thickness straight vane rotor with No Scalloped type permitted. Pad surface must be smooth with no lightening, coating, or heat disbursement machining. Stock OEM gm steel calipers must operate on all 4 wheels and lock on inspection. No floating brake calipers permitted. Brake bias adjuster is allowed. 1 working brake per wheel.

**Weight:** All lead weights must be painted white with clearly marked on it. Lead ballast must be mounted between the rear axle and a imaginary line drawn through the front axle.

**Accessories:** Cars will not be permitted to carry on board computers, micro-controllers, processors, recording devices, electronic memory chips, traction control devices, digital readout gauges or GoPros.

**No cell phones, Bluetooth watches, or any other kind of electronics in the car during competition**

**Radios:** Radios must be of two-way voice communication type only, independent of the car's electrical system. **All teams must have 1 scanner programmed to receive the PASS race control frequency and must have a crew member always monitoring this channel during every PASS event. This crew member must be able to communicate directions to the driver via the two-way radio.**

**Wheels:** Steel 8" or smaller racing wheels only allowed. Minimum 5/8" wheel studs are required on the right side of the car.

**Bleeders:** No bleeders or air leaking devices in wheel just a valve steam

**Tires:** Hoosier 500 left side and 700 right side 9" slick tire. You may run 700 anywhere on the car but the 500 must remain on the left.

**Tire Policy:**

**Transponder:** Transponders are mandatory and must be mounted 11' from the back of the rearend tube (see PASS website for description)

**Lettering and Numbering:**

- a. Car numbers must be a minimum of 18 inches high and 3 inches wide. Numbers shall be placed in contrasting colors to the car on both doors and roof. No reflective chrome, gold,

or prism numbers allowed. Roof numbers must be visible as read from the grandstand side of the car.

- b. The car number must appear in 6" high numbers in the uppermost corner of the windshield on the passenger side and on the right rear taillight cover.
- c. All cars must display PASS promotional stickers in the proper assigned placement location. To include PASS windshield stickers centered on upper windshield as well as contingency sponsor stickers to be located on both front fender areas as indicated by tour guidelines. 10% of event winnings will be deducted from teams that do not display proper promotional stickers in approved and specified assigned location during event.
- d. Any signage deemed inappropriate by PASS must be removed before a car is allowed on the racetrack.
- e. Car number must be approved by PASS. Numbers for Tour drivers from the previous season will be held for renewal until January 1 of each year. New numbers will be assigned on an available basis. Car number application forms are available from PASS.

**Illegal Parts:**

- a. Any part found illegal will be confiscated and become the property of PASS.
- b. Any competitor found to have an illegal part will not be allowed to compete in any PASS event until that part is surrendered to PASS series officials.

**NOTE: ANY ITEMS NOT DESCRIBED AS ALLOWED IN THESE RULES SHOULD BE DETERMINED AS ILLEGAL UNLESS PASS ISSUES A BULITEN EXPRESSING OTHERWISE.** Additional weight penalty or disallowance from competition for non-conforming rules infractions. Weight added to be determined series by officials in interest of parity of competition

Points awarded as follows:

Any team that is licensed and signs in at any given event is awarded 50 bonus points per event entered:

All Teams are required to sign in at designated area (typically tech) at time of arrival at each event. Any team that has not signed in by 1 hour prior to completion event start time will be placed at the rear of both the heat and feature events for given date of competition. It is YOUR responsibility to sign in.

Event points will be awarded as follows:

Qualifying Heat: 1st – 5pts    2nd – 4pts    3rd - 3pts    4th – 2pts    5th – 1pt

Feature Event:	1st 50 pts	9th 34 pts	17th 18 pts
	2nd 48 pts	10th 32 pts	18th 16 pts
	3rd 46 pts	11th 30 pts	19th 14 pts
	4th 44 pts	12th 28 pts	20th 12 pts

5th 42 pts	13th 26 pts	21st 10 pts
6th 40 pts	14th 24 pts	22nd 8 pts
7th 38 pts	15th 22 pts	23rd 6 pts
8th 36 pts	16th 20 pts	24th 4 pts