



2020 PASS MOD Rules

2020 PASS MOD Tire policy

Each team will start the season with 4 new race tires that will be registered with tech. These will be registered as your 4 race tires for race number 1. You can have 2 tires for spares. Spares are only used in case of a puncture or a flat. This must be authorized by tech. Race number 2, You will be able to buy 2 tire and this must be run the night of purchase. (This will give you 2 good spare tires in case of a flat) Race number 3, You will be able to buy 1 tires and these must be run the night of purchase. Race number 4, You will be able to buy 2 tire and this must be run the night of purchase. Race number 5, You will be able to buy 1 tires and these must be run the night of purchase. This sequence will continue throughout the season unless otherwise specified in drivers meeting. For every tire you purchase, 1 must be eliminated from the total 4 race tires registered. The 4 race tires each week will have to be registered prior to any qualifying and have to be run in all qualifiers, consolation rounds and main events. There will be no more than 2 new tires on a car at any given time. At the end of each race the top 5 finishes will have 30 minutes to bring the 4 race tires from their car to tech/tire truck to be confiscated until the following race. These tires will be released to their prospective teams at the following event bidding no illegal issues.

2020 Rules Changes and Clarifications

Minimum wheelbase 107". This will be measured with the PASS Referee from hub to hub.

Deck Lid: The deck lid must remain no lower than the bottom of the spoiler and carry forward at least 30" in a parallel form. The rear deck is not to sunk down and used as an additional spoiler or air deflection device in any way. Picture below reflect a typical rear deck design.

Front nose is to be no higher than the top of the air cleaner at any point.

NO Panning!

3. If using stock type clutch, car must be equipped with explosion proof steel bell housing. If using multi disc clutch you may use standard **OEM** style bell housing. No mini reverse starter style bell housings.

8. GM crate engine p/n 88958602 is mandatory in full untouched factory form from intake to oil pan. The only change from production will be that of replacement oil pan Moroso p/n 21319 7.125 depth and matching oil pump p/u assy or gm factory 604 oil pan part number 25534354 used with 1/8" thick plate tack welded to the bottom of the pan to equal the same depth as the Moroso p/n 21319 7.125 (gm 25534354 7" depth + 1/8" plate = 7.125 total)



10. GM Crate Engine 603-ZZ4 will no longer be allowed for competition.

Front clip:

A fabricated 2x4, 12 inch perimeter tubing: 0.095 inch wall thickness "F" body Camaro front clip will be permitted without weight penalty. Measurements and Template from the Howe 358-8-01 will be used as a "GO/NO GO" guage. This clip is designed for Stock lowers and steering box placement and use. Clip must retain 2x4 box from front to rear. NO 2x3 step in suspension area. Port City style 2x4 is NOT PERMITTED.

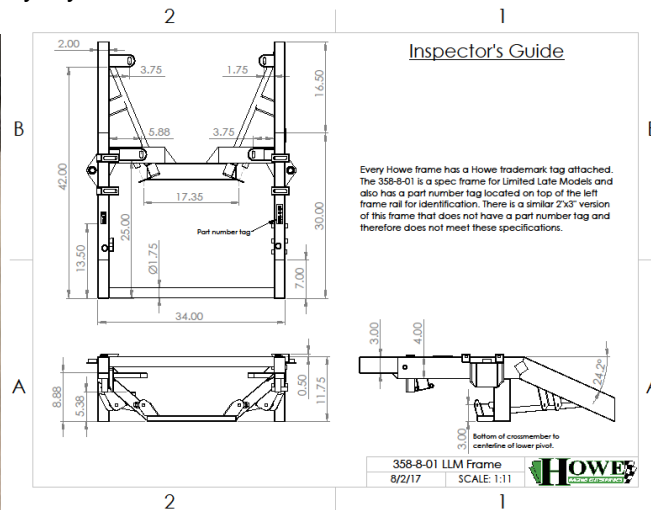

Rear frame may be altered to accept leaf, coil spring, or coil-over. . No fiberglass graphite or exotic springs permitted. Must be of magnetic steel be a maximum retail cost of \$120.00 ea "leaf spring max cost is \$175.00 ea" No fiber glass lift bars. No torsion bars in rear. **The rear center link may be a solid link or mounted in rubber bushings. No spring third links or trailing arms allowed.** No hydraulic, ratchet, or electric weight jacks anywhere in or on car." No Bird Cages"

2020 Rules and Specifications

Safety

1. Electrical Kill switch required within easy reach of the driver. Switch must say "ON" or "OFF".
2. Helmets are required and must be approved SCCA or Snell 95 type full coverage. Head/neck restraint devices are highly recommended.
3. Fire suits of flame retardant nature must be worn by all competitors. Suit must be current and free of defects. Fire resistant gloves required. Fire resistant foot wear is highly recommended.
4. Only one battery permitted. Maximum 16 volts. Must be mounted securely outside driver's compartment.
5. All cars must have fuel cells, 22 gallon maximum, in completely enclosed minimum 22 gauge steel container. All cells must have a minimum of two 1/8" X 2" steel straps surrounding the. Fuel cell must be

protected in rear of axle by roll cage tubing mounted securely. No part of fuel cell can be lower than protective tubing. Fuel cell guard pipe must be lower than fuel cell installed height. Must be a minimum of 8 inches from track. Fuel cell vent must have roll over valve in cell or in line.

6. Belts must be racing type quick release and must consist of a lap belt, shoulder harness and sub strap. Belts must be a minimum of 3" and NO MORE THAN 5 YEARS OLD. Drivers utilizing neck restraint devices are permitted 2" shoulder straps but remaining required harnesses must be 3".

Belts with no dates will be considered too old. Belts must be properly mounted to welded steel plates and not through tin, aluminum, floor, or bulkhead.

7. All cars must have a minimum 5 lb. fire extinguisher/suppression system within drivers reach.

8. Only approved Racing seats are permitted.

9. Quick release racing design window safety net is required.

Bodies

1. Bodies may be Tempo, Cavalier, Mustang, Daytona, Gremlin, etc. American passenger cars only. No panel vans or station wagons. Rear window area must be open. Must be full sized roof. Rear side quarter windows must be either open or clear Lexan. No other side window boxing permitted. Must have full, half or capsule type Lexan windshield. If running half of capsule type you must have guard on passenger side. All Chevy Motors only - may use any body style.

1a. Fivestar mod body is permitted but must adhere to the Deck lip not to extend more than 45" behind center of rear axle and to be the same height as quarter panels

2. Firewalls and floorboards and mandatory. The driver's compartment tub (to the right and to the rear) to be constructed from a minimum of 22 gauge steel or .040 aluminum. The driver's foot box and firewall to be constructed of a minimum of 22 gauge steel. Fiberglass or metal duplicate of body parts are permitted. Handmade or after market body parts may be constructed of steel, aluminum, or fiberglass. No body part may be closer than 4" to the ground. No side skirts. Right rear quarter panel to be no further than 2" to the inside of the inner sidewall of tire. All body panels behind rear axle housing must maintain a minimum ground clearance of 8 inch's.

3. Original roof line of vehicle should be maintained with a maximum 2" drop, rear to front. No wings. No air flow devices to direct air allowed. No ground effects allowed inside or outside of vehicle. Both side windows must have a minimum of 12" vertical opening from front to back. Roof height must be minimum of 44 inches. May run 5" high spoiler, 66" across, to be located at the rear of the deck lip. Deck lip must be 70 to 90 degrees of spoiler. Maximum rear spoiler height from ground to top most edge is 39 inch's. Maximum height of door / quarter ledge is 34 inch's measured from the ground to top edge. Deck lip not to extend more than 45" behind center of rear axle and to be the same height as quarter panels as not to act as air tunnel for spoiler. The top 4" of spoiler must be made of clear Lexan. Competitors must be able to see through spoiler.

c-Post/ Sail panel must stop 12" before spoiler. It is not to extend back to spoiler.

Deck Lid: The deck lid must remain no lower than the bottom of the spoiler and carry forward at least 30" in a parallel form. The rear deck is not to sunk down and used as an additional spoiler or air deflection device in any way. Picture below reflect a typical rear deck design.

Front nose is to be no higher than the top of the air cleaner at any point.



4. Nose / front bumper: Nose panel may not exceed the width of the front clip utilized. Nose forward ball joint location width dimension Maximum width shall be 42 inches and minimum shall be 34 inches but may not extend more than width of clip utilized. Five star pavement mod body is legal with 36" max overhang. No part of the car shall have a forward overhang of more than 36 inches as measured from the front spindle pin forward. No part of the body may extend forward of the front bumper. Maximum front bumper length not to exceed 18 inches from mounting point on chassis. Front bumper must be mounted frame end to frame end, with bottom loop parallel to the ground. Minimum 1 – 1/4 " pipe able to support car if lifted by wrecker.

5. Rear bumpers may be constructed of tubing, channel or flat stock, and must protect fuel cell. Center of bumpers (front and rear) must be 18" from ground (Tolerance 2"). Rear bumpers and nerf bars, must not extend more than one inch beyond width of rear tires and must not contain any sharp edges. Rear bumper tethers or safety cable is mandatory, must be attached to both bumper and rear chassis to prevent bumper from being dislodged.

5. Engine compartment will remain open. No side panels. Hood sides may have a maximum 4" drop and must be enclosed at rear of hood. Bodies should extend no further forward than back of block. Rear of bodies to be solid panel at least 8" high with car number.

Roll Cage

1. Roll cage must consist of continuous hoops not less than 1 – 3/4" outside diameter and must have a wall thickness of at least .095. Must be frame mounted in at least 6 places. Cages will be sonic tested if necessary. Main frame rail structure of chassis, defined as the primary structure to which roll cage members, major suspension components, etc., mount to, must be constructed of a mild steel shape having a minimum perimeter dimension of 10 inches. Chassis with stock frame rail extensions are exempt from perimeter dimension on right side rail.

2. Must consist of a configuration of front and rear hoops connected by tubing on the sides or side hoops. Driver's head must not protrude above cage with helmet on. Roll cage must be securely supported and braced. Top hoop must have crossbar. Minimum height from ground to top of roll cage 43", with 3 inch frame height.

3. Protection of the feet is mandatory. Bar across back of engine with vertical bars and rub rails or similar protection.

4. No brace bars forward of the main 4 point cage may be higher than stock hood height.

5. Driver door bars must be as parallel with the ground as possible and located perpendicular to the drive so as to provide maximum protection for the driver, but without causing difficulty in getting in or out of vehicle. The side bars must be welded to the front and rear of the roll cage members. Door bars less than .095 thickness should have 4 bars at least 1 – 3/4" diameter. Driver side door cage must be plated with 1/16" steel from top door bard down to frame, must be welded on outside. Right side 3 bars or X method. If door bars are not plated and car loses side panel you will be black flagged.

6. All ground clearance measurements are to be measured with driver in car.

Chassis/Suspension

May be offset chassis or straight up. Minimum wheel base 108". No tube type clips allowed. Maximum 58% left side weight. Added weight must be securely bolted inside of frame rails, behind front spindles and in front of rear axle. No weight inside driver's compartment. No more than 200 lbs of bolt on ballast weight permitted. Loose objects must not be used in driver's compartment. Mounted ballast must be painted white with car number on it. In the event ballast comes off your car and ends up on the racetrack you may be assessed a \$200 fine. All ballast must be lead weight only. Tungsten is not permitted. This does not apply if the car is involved in an accident. All weight must be attached with a minimum of 2 3/8 inch grade 8 bolts.

Front clip.

Factory production full 1968 or newer perimeter American passenger car front frame clip only. Frames may be cut in rear only at a point not further than 36" from center of rear end housing. No Jeep, Bronco, or 4 wheel drive frames allowed. No front wheel drives. Metric frames are ok. Also Camaro or Nova Clips or you may run Howe stock Replacement Camaro clip Part# 358-8-01 stock lower a frame suspension mounting points. . Clip must retain 2x4 box from front to rear. NO 2x3 step in suspension area. Port City style 2x4 is NOT PERMITTED.

When mounting Camaro or Nova Clip or Howe replacement a minimum measurement from lower control arm to tube frame 24-1/2 inches. No modifications to clip permitted with the exception of upper control arm mounting, spring pocket boxing for clearance of use of coil over mount shock/spring, radiator clearance and mounting and trimming of forward front cross member for center link clearance. Stock clip must extend forward in stock produced form beyond all suspension mounting

points to include steering box and idler arm mounting positions. Cars with fabricated "horns" may be subject to an assigned weight penalty.

NO cutting, raising, shortening, ect of factory front cross member. If yours has been cut then a solid bar or 1/8" thick box plate must be securely welded to the bottom of the cross member to replicate it's stock height and dimension.

Maximum tread width front and rear is 76 inches, measured from outside of wheel edge to outside of wheel edge as measured at the bead lip of the wheel. ONLY authorized solid wheel spacers allowed. The front is measured at the front of the wheels, the rear is measured at the rear. The track or technical inspector's gauge is the final word. Frames may not be widened or narrowed and must be able to support cage on both sides. Must be full and complete on both sides. Minimum frame height from ground is 3". No other part of the car may be lower than 3".

Front / rear suspension must in stock location. Heim ends permissible. Also may run tube type tie rods, and stock or aftermarket center link. Stock passenger car spindles only. No fabricated spindles. No alterations (welding or heating) allowed on spindle arms. No Howe cast spindles. Aftermarket dropped spindles are permitted but are limited to the following: Bell tech part #2100 and Classic performance part#7078ds. Bottom A frames cannot be altered or moved. Lower control arm bushings are limited to stock, steel or neoprene type only. No spherical bearing or heim end bushing type permitted. Tube type upper A frame allowed, can be moved and adjustable. Jacking bolts allowed. Conventional coil spring and shock, or coil-over suspension allowed. Must be steel shock. One steel body shock per wheel only. Only shocks with a racer list price of \$125 or less may be used. No threaded shocks. No adjustable or rebuildable shocks permitted. No modification to any shock permitted. Any shock utilized must be as manufactured and may be subject to testing per request of series officials. Coil-over suspension must use coil-over conversion kit.

Rear frame may be altered to accept leaf, coil spring, or coil-over. . No fiberglass graphite or exotic springs permitted. Must be of magnetic steel be a maximum retail cost of \$120.00 ea "leaf spring max cost is \$175.00 ea" No fiber glass lift bars. No torsion bars in rear. **The rear center link may be a solid link or mounted in rubber bushings.** No spring third links or trailing arms allowed.

No hydraulic, ratchet, or electric weight jacks anywhere in or on car." No Bird Cages"

Brakes: Hubs – rotors: front must be of stock OEM heavy duty type only. No aftermarket replacement hubs. Rear may be either stock, flange hub type or hat design. Must be steel. Aftermarket type must as produced and be a minimum .810 thickness straight vane rotor with No Scalloped type permitted. Pad surface must be smooth with no lightening, coating or heat disbursement machining.

Minimum wheelbase 107". This will be measured with the PASS Referee from hub to hub. No tube type front clips allowed. No aluminum or fiberglass suspension or rear end parts. No aluminum driver shafts. Drive shafts must be painted white. No titanium parts may be used anywhere on car.

Chassis weights according to configuration:
(All weights with driver, before race, race ready.)

Metric / Camaro/ nova/ impala snout - coil spring or coil over with crate engine - 2600 lbs.
Howe Camaro replacement 2x4 .095 front clip will be allowed in it complete at 2600 lb.

Steering box must be OEM. Must utilize 700 series steering box only. NO rack and pinion. No aftermarket design steering box. Must remain within original bolt pattern for type of frame used. Pitman arm must be stock or aftermarket similar replacement. In cockpit steering may be modified to suit driver's taste, but must be on left side of cockpit. No center steering. Collapsible steering column highly recommended. A single In line steering quickener is permitted.

Steel wheels only. No plastic carbon fiber wheels. All rims must be 15" X 8". No tire bleeders.

Brakes must operate on all 4 wheels and lock on inspection. All calipers must be stock OEM! No floating brake calipers permitted. Brake bias adjuster is allowed. 1 working brake per wheel.

Sway Bar: Sway bar may be stock, one piece aftermarket or 3 piece aftermarket design. All components must be steel. Rear sway bars are Not permitted. Weight jacks must be in original centerline with coil springs.

No carbon fiber or titanium parts are permitted.

Bearings: ALL bearings are to be oem production design bearings. Rollerized or roller bearings are not permitted unless factory equipped for all individual intended bearing uses.

Springs: All springs must be magnetic steel only and not to exceed \$200.ea

Aluminum parts: No aluminum wheels, hubs, "A" frames or spindles or any aluminum suspension parts. The only aluminum parts in suspension that are permitted are as follows: Lower spring cups rear, coil over kit assembly (to include cup-nut sleeve), chassis mounted panhard and 3 point bar adjuster, trailing arm tubes, 3 point tube, front upper control arm cross shaft and tie rod sleeves. All Rod ends are to Be STEEL.

Engine/Drive Line

1. Only OEM production type transmissions will be allowed. 3 speed or 4 speed and automatic. No 5 speed. No in and out boxes. No buttons or couplers. Must be clutch operated. Clutch or torque converter must be inside of bell housing. Shift with motor running imperative! Multiple disc clutches are permitted. Minimum disc diameter is 7 1/4 inches, steel discs and pressure plates only, must mount to back of engine in stock location. Any steel flywheel permitted. Clutch must be mounted inside of bell housing. No Jericho type or straight cut gear type transmissions permitted.

2. Transmission must have at least two gears forward and one reverse gear, and must have neutral. All race cars must join lineup on demand, unaided, or go to rear of race. 4th gear must be 1 to 1. **No other gear may be higher (numerically lower)than 1.23 in transmission.**

3. If using stock type clutch, car must be equipped with explosion proof steel bell housing. If using multi disc clutch you may use standard **OEM** style bell housing. No mini reverse starter style bell housings.

4. Driveshaft must be steel only. Painted white.

5. Drive shaft loop is required and must be constructed of at least 1/4 inch X 2" steel. Must be mounted no more than 6" back from front of driver shaft.

6. Gear rule: Maximum 5.38 direct or final drive. For tracks 1/2 mile or larger a gear rule will be mandated.

7. Any passenger OEM car type or truck rear end may be used. No aluminum allowed, except for lowering blocks or axle cap. No quick change devices allowed. No titanium or magnesium permitted. Locked rear end,

spool type only. No ceramic coating of internal rear end or transmission parts. All rear ends must have racing axle for safety if not floater. Ford 9" rear recommended. Stock open(non posi) carrier is permitted, use of steel mini spool is permitted. If you run a floater you must run steel hubs and steel drive plates, no aluminum.

8. GM crate engine p/n 88958602 is mandatory in full untouched factory form from intake to oil pan. The only change from production will be that of replacement oil pan Moroso p/n 21319 7.125 depth and matching oil pump p/u Assy or gm factory 604 oil pan part number 25534354 used with 1/8" thick plate tack welded to the bottom of the pan to equal the same depth as the Moroso p/n 21319 7.125

(gm 25534354 7" depth + 1/8" plate = 7.125 total)

Before mentioned oil pan is the only legal replacement permitted.

Must run stock as produced 8" harmonic balancer

8a. Crate engine rebuild specifications:

GM '602' Crate Engine Inspection Policy

Within the guidelines of utilizing the 'Crate'-Race engine options all competitors are subject to a zero tolerance policy of inspection and conformability to all guidelines as specified by the manufacturer.

If in the event any team is considered in question as to the productivity of performance from a 'crate' powered engine, that engine will be susceptible to the following inspection process without protest. Failure to adhere to any action taken by PASS series officials will result in immediate disqualification.

At the conclusion of any race event PASS reserves the right to require any team to remove engine in complete form and turn over possession to appropriate officials for inspection purposes to be determined by officials.

Engine will be susceptible to Dyno testing and/or engine tear down for complete inspection to determine total legality to factory produced complete form.

In the event ANY part within engine is found non-conforming, the entire engine will become the possession of PASS without claim or dispute. An additional \$1,000.00 fine will be assessed to violating team before next event in which said teams attempts to compete.

In the event of engine rebuild the only modifications are listed below.

Maximum overbore of .008"

Maximum Deck surfacing of block: .005"

Maximum deck surfacing of cylinder head: .005 straight only. NO angle milling permitted.

Minimum rod and main bearing size: .010" under

Double row timing chain permitted

All other necessary parts required for rebuild are to be direct factory replacement purchased through Manufacturer and are exact OEM specified part numbered to engine utilized specification sheet and installed to factory built specs. NO EXCEPTIONS!

Replacement of GM seal bolts is not mandatory. Standard grade hardware in place of sealing bolts is permitted.

All crate engines are to be used in complete form as produced unless otherwise specified. From Intake manifold to oil pan. No external oiling systems permitted.

ZERO TOLERANCE!

9. **NON Crate engine option:**

2 Barrel engine option specifications

Block: stock, maximum .045 overbore production blocks only. No angle milling permitted. Only modifications permitted are standard boring and decking only.

Crankshaft: stock production steel only. Stock stroke \pm .020. No Knife edging or lightening permitted. Only nominal engine balancing permitted. Minimum allowable weight shall be 50 lbs. Rod and main journals must remain OEM size.

Camshaft/Lifters: Hydraulic cam and lifters only. Maximum allowable lift is .450" measured at the valve.

Roller bearings are NOT permitted.

No roller cam/lifters.

Pistons: Flat top skirted pistons only. Maximum allowable compression is

10.99 to 1. 2 or 4 valve pocket full skirted pistons permitted. Piston may not protrude above edge of cylinder block surface.

Connecting Rod: Stock or sportsman type connecting rods only. Stock length for engine used.

Oil pan: racing type pans allowed. Wet sump only. Maximum 7 quart capacity. Minimum depth of pan from mounting rail to base of pan shall be 7 inch's.

Oil Pump: Factory stock mounted internal wet sump type only.

Intake: Factory cast iron 2 brl. or the following Edelbrock performer intakes are permitted. G.M.= 2101, 2116, 7116 Ford= 2181. No porting, polishing or modifications permitted (Including chemical porting). Port matching is NOT permitted.

Cylinder heads: stock production steel cylinder heads only. No bowtie allowed. Heads must remain stock with the exception of the Installation of screw-in rocker arm studs and push rod guide plate installation permitted. Maximum valve spring outside diameter shall be 1.250 inch. Head must retain stock valve size for casting used. Maximum Intake valve diameter 1.94". Maximum Exhaust valve diameter 1.50". Stud girdles are not permitted. Angle milling is NOT permitted.

No porting, polishing or modifications permitted (to include chemical porting). Port matching is NOT permitted.

Roller rockers are permitted. 1.5 ratio only.

Timing Chain: Stock replacement or double roller chain permitted.

Harmonic Balancer: Stock production only.

Maximum engine static compression permitted limited to a maximum of 10.99 to 1.

No Aluminum or Titanium parts permitted unless otherwise listed.

Any specific part not listed within these posted rules must remain O.E.M. manufacturer replacement parts only.

Carburetor: Holley 4412 2barrel. Only modification's allowed to carburetor will be the removal of choke plate and shaft. Maximum 1 inch carburetor spacer only. no tapered or beveled spacers permitted. I.D. must remain consistent through spacer depth from top to bottom.

All other posted engine accessory as well as standard rules apply unless otherwise detailed.

This engine package is permitted at a competition weight of 100 lbs more than permitted crate engine option for initial competition. PASS reserves the right to add or subtract given weight assignment in the effort of fair and equality within allowed engine options. This option will be in constant evaluation through competition and result.

a. Carburetor. 650 cfm. Holley p/n 80541-1 or -2 Direct bolt to intake or 500 cfm Holley 4412 only. No modifications from factory production other than removal of choke plate and jet size.

Exhaust System Exhaust system must be mounted in such a way as to direct spent gases away from areas of possible spillage of fuel. Headers may be used but must be pointed away from the ground. All cars must have a working muffler, passing a maximum of 100 decibel noise test 50' from the track. Exhaust may exit by the nerf bars but may not extend beyond them. Exhaust must be collector type header. No 180 degree headers allowed. Left exhaust header must exit on left, right header on right side. Only headers allowed are IMCA type - no cross over headers.

Muffler Rule: Must run Schoenfeld Part #112535 3.5"x11" or Part #112530 3.0"x11"

c. Air filter. Maximum size 17 inches outside diameter by 4 inches high. No flow enhancers or cold air induction permitted. No notching of cowl, back of hood must seal to cowl top.

d. Fuel pumps. Only stock type, mechanical fuel pumps, mounted in stock position. No electrical pumps.

Fuel:

Only Sunoco standard (purple) race fuel permitted or pump gas only.

Engine placement:

Stock motor mounts may be replaced with solid mount. Motor must be a minimum of 72 inches from the center of the rear end to the rear of the engine block. Engine offset must be kept within 2" of the centerline of the cross member (within 1" of center). Minimum Crank height from center of crank to ground: 11 inches.

Ignition system:

Any battery powered ignition system produced for highway use is allowed. No crank trigger systems, no magnetos, boosters or other devices allowed. One working coil only. No aftermarket electronic ignitions allowed. No systems with external box allowed. Battery must be securely fastened inside the main frame rails and outside of cockpit. Battery must have protective cover. GM HEI stock type distributor only.

Cooling system:

System may be modified. No anti-freeze permitted. Only belt driven block mounted OEM similar design water pumps permitted. Belt driven fan blade or electric cooling fan are permitted.

Aftermarket racing power steering pump and any design tank are permitted.

MISCELLANEOUS

1. Radios are optional, and if used, frequencies must be supplied to the technical inspector prior to race event. Frequencies are subject to be scanned during race event.
2. Mirrors are allowed and are NOT to be used for blocking purposes.
3. Wheels: no wide fives, 8" Steel conventional only.
4. Side bars, Nerf bars. All sidebars should run parallel to the ground and have rounded ends. Sidebars not to extend more than one inch outside of tire.
5. All rules are subject to change if it becomes necessary to keep competition equal or for safety issues.
6. Spill boards, vertical or airfoil or any other aerodynamic devices will not be permitted anywhere on the car.
7. Tech reserves the right to add or subtract weight to keep competition equal.

Lettering and Numbering

Car numbers must be a minimum of 18 inches high and 4 inches wide.

Numbers shall be placed in contrasting colors to the car on both doors and roof. No reflective chrome, gold, or prism numbers allowed. Roof numbers must be visible as read from the grandstand side of the car.

Multiple drivers using same numbers are NOT permitted. Number assignment is established through licensing authorization. In the event a driver utilized a number in the previous season it is most likely not available. Series officials may issue previously utilized numbers in the event that number may become available. Any signage deemed inappropriate by the event official's must be removed before car is allowed on the racetrack.

Car number must be approved by the event promoter. Numbers for team from the previous season will be held for renewal until February 1st. of each year. New members will be assigned upon request on an available basis. Car number application forms are available @ www.proallstarseries.com.

Any team(Driver) must be licensed and display all event promotional stickers to be eligible for possible available provisional starting positions as well as any licensed team bonus points per event earned by licensed teams.

Forward Door as well as top of windshield must be available for promotional sticker placement as presented in promotional pack. All necessary stickers will be available through event promoter or event officials at race events.

Any driver/team that is not licensed is required to file single event entry at teams cost of \$25 per event.

Competition points:

Awarded as follows:

Any team that is licensed and signs in at any given event is awarded 50 bonus points per event entered:

All Teams are required to sign in at designated area (typically tech) at time of arrival at each event. Any team that has not signed in by 1 hour prior to completion event start time will be placed at the rear of both the heat and feature events for given date of competition. It is YOUR responsibility to sign in.

Event points will be awarded as follows:

Qualifying Heat: 1st – 5pts 2nd – 4pts 3rd - 3pts 4th – 2pts 5th – 1pt

Feature Event:	1st 50 pts	9th 34 pts	17th 18 pts
	2nd 48 pts	10th 32 pts	18th 16 pts
	3rd 46 pts	11th 30 pts	19th 14 pts
	4th 44 pts	12th 28 pts	20th 12 pts
	5th 42 pts	13th 26 pts	21st 10 pts
	6th 40 pts	14th 24 pts	22nd 8 pts
	7th 38 pts	15th 22 pts	23rd 6 pts
	8th 36 pts	16th 20 pts	24th 4 pts

Event line up format:

Any NEW driver to the series is mandated to start at the rear of the field in both the heat and the feature for their first event.

Any driver that does not compete in the season opening event will start the rear of their first event in that given season.

Opening day for each season all drivers that accumulated points in the previous season will draw for heat starting positions. Feature event for that event will be determined by heat finishing positions.

Heat and Feature event line ups are determined by each drivers (DPR) Driver performance Rating (average). DPR points are only competition awarded points and bonus licensed bonus points are not calculated into the formula.

This is calculated buy the amount of competition points earned to date divided by the number of event starts made.

Example:

Driver X earned 300 competition points during 8 events his DPR = 37.5 300 divided by 8 = 37.5

Line ups are assigned with driver with the lowest DPR average starting at the front and driver with the highest average at the rear.

Feature winner shall start the rear for next event in competition. Should a driver miss the next event that winner will start the rear at next event they attempt to compete in.

Any competitor that wins 2 or more events during a given season may not start any better than tenth in feature event even if their earned DPR is rated lower than that given position.

Definition of an entered event mandates the presence of the car and driver at the given event with ability and intent to compete. Having signed in and attended the event.

Any driver that misses more than one event per season will have to start the rear for the next given event attended.

Race Procedures

All Race procedures may be found under the SLM section on the proallstarsseries.com web-site with the exceptions of the following.

Lucky dog rule is not in use within the events of the mod series.

For technical questions concerning rules call Charlie Rockwell 802-754-2822.